



## Abatement & Demolition Elements

- Protect health and safety of public and workers.
- Remove asbestos, hazardous materials and demolition debris.
- Conduct worker and community air monitoring
- Decontaminate all building interior surfaces.
- Remove building to slab elevation.
- Manage truck traffic and haul routes.
- Continue to protect public at all times.



WORK AREA PREPARATION



WASHING OF BUILDING INTERIOR



POLY LINED TRUCK FOR ACM TRANSPORTATION



COLLECTION OF WASH WATER

## AIR SAMPLING

- Within Work Area
- Outside Work Area
- Worker Exposure

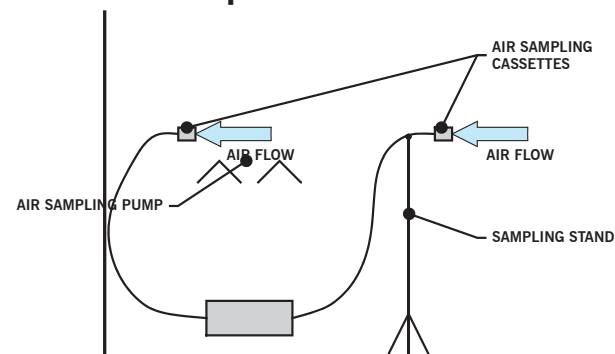

## ENGINEERING CONTROLS AND REMOVAL PROCEDURES

### Contaminated Work Area with Negative Air Unit

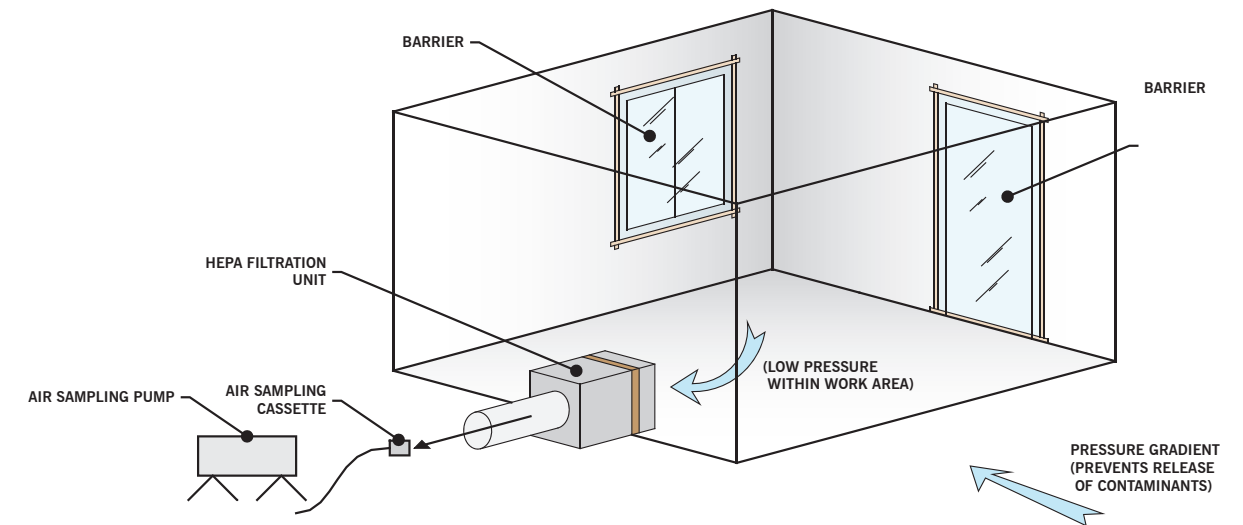

### Decontamination Unit

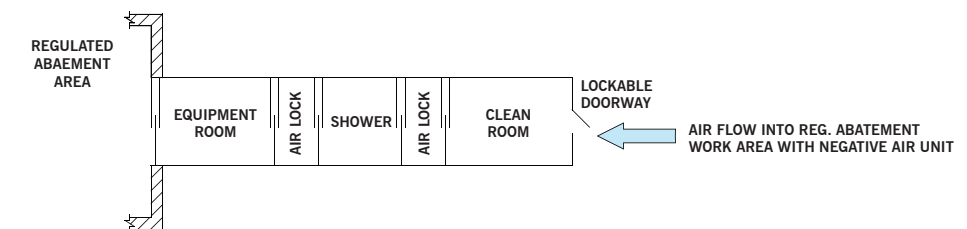

## PROJECT REGULATORY COMPLIANCE

- New York State Department of Labor
- United States Environmental Protection Agency
- Occupational Safety and Health Administration
- New York State Department of Environmental Conservation (Waste Disposal)

## What to Expect

- Cranes
- Large Equipment
- Rigging and Hoisting
- Dust Suppression
- Utility Work
- Perimeter Fencing
- Sidewalk Closures



RIGGING AND HOISTING



PERIMETER FENCE



SIDEWALK CLOSURE



LARGE EXCAVATORS



DUST SUPPRESSION

# Albany Central Warehouse Site Restoration

